

200+ Patent Certificates
\$1,000,000+ Annual Energy Saving
20,000+ Projects Successfully Installed



3 Years
Payback Period



Modular Solar Lamp Pole Optional

HIGH LUMEN
OUTPUT UP TO **200** lm/W

SL-OT Series SunGuard Solar Area Light

Shoebox / Parking lot lighting Power: 115W/145W



Innovative & Tailored
Lighting Solutions for **Success**
www.NationalLED.com

SL-OT Features

Flexible Battery & Solar Panel Installation Options



Battery Solution A:
Battery Integrated with Solar Panel System



Battery Solution B:
Battery Installed on the Lamp Poles

Easy & Quick Connection

Hybrid Grid Power Solution Optional

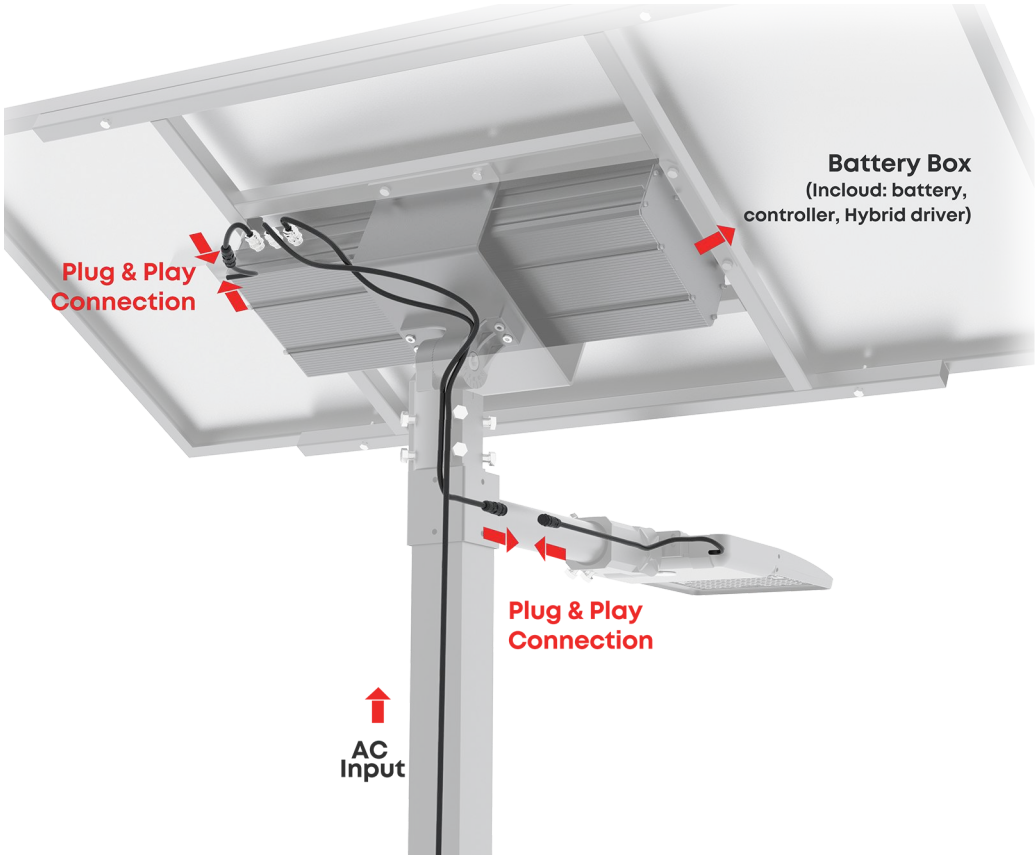

Special Design for **Parking Lots**







WARRANTY

3 Year Limited Warranty,
5 Year Preferred Warranty.
Please consult with our sales for detailed agreement.

- It features a lens that is precision engineered using optical grade Mitsubishi PMMA for maximum light intensity.
- A variety of light distributions including Type III, Type IV, and Type V, ensuring precise photometrics for the right project.
- A buckle design and tool-free maintenance, making it easy to maintain. The top cover is reserved for a photocell sensor, and the bottom is reserved for an occupancy or PIR sensor with a waterproof seal.
- Delivers improved visual comfort by lower glare and providing a wider smoother and more uniform light output. BUG=0.
- Minimum CRI of 70 and 80 optional.
- Cutoff classification: Cut-off, no up light pollution.
- It offers the option of customized pole adapters for special installations. This allows for greater flexibility and customization during the installation process.

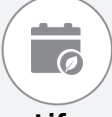
Advantages of SL-OT Solar Area Light

 <p>Professional Distribution Options</p>	 <p>Exclusive Rotatable Lens design</p>
 <p>Monocrystalline Silicon Solar Panel</p>	 <p>Solar Panel Integrated with Battery Box Optional</p>
 <p>Long Lifespan Li-ion Battery & MPPT</p>	 <p>Intelligent Lighting Control</p>

 <p>PATENTED PRODUCT</p>	<p>UP TO 200 lm/W</p>	<p>WORKING TEMPERATURE ENVIRONMENT -10°C~50°C (14°F~122°F)</p>
<p>IP65</p>	<p>3000K 4000K 5000K 5700K 6500K</p>	<p>CRI Ra70/80</p>
<p>L90B10 >100,000HRS @ 25°C</p>	<p>ULR = 0%</p>	<p>SMART SENSOR OPTIONAL</p>
<p>Optional REMOTE CONTROL</p>	<p>IoT-4G / ZigBee OPTIONAL</p>	<p>DIM</p>

Key Components

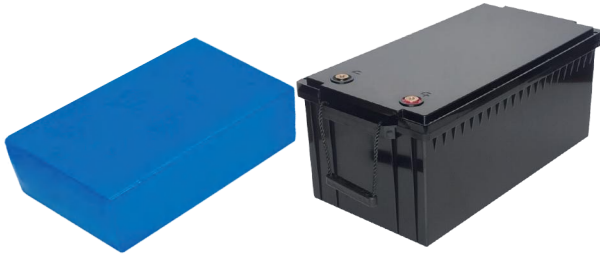

LiFePO4 Battery

Uses LiFePO4 batteries, enduring over 2000 charge/discharge cycles for safety, compactness, and longer lifespan.



High Power Solar Panel

Utilizes multi-busbar (MBB) half-cell technology, reaching up to 200W power, maximum Efficiency can reach 20.2%.



MPPT Controller

All power control and management use the MPPT solar controller, boosting charging efficiency by 30% compared to PWM and ensuring more stable performance.

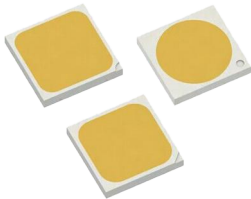

High Efficiency LED Chips

It uses ultra-high brightness LED chips to provide the best lighting performance with minimal power consumption.



Optics Lens

The distributions design focused on the road's center, reducing light pollutions. Various lens patterns are available to meet different project needs.



Cable Connector

IP68 multi-point connector, cooper tin-plated, flame retardant rating: UL94-VO, easy and durable connections with any solar panel.



Advantages of Solar Panel

High Power

- Utilizes multi-busbar (MBB) half-cell technology, reaching up to 200W power, maximum Efficiency can reach 20.2%.
- Higher module power effectively reduces system BOS (Balance of System) costs.

High Reliability

- Enhanced PID (Potential Induced Degradation) resistance through optimized cell processes and material control.
- Resistant to salt mist and ammonia.
- Passed mechanical load tests with 5400 Pa on the front and 2400 Pa on the back.

High Energy Yield

- Third-party verified excellent IAM (Incident Angle Modifier) and weak light response performance.
- Lower temperature coefficient and lower operating temperature result in higher energy output.
- Half-cell technology provides better shading resistance.



200W

Maximum Output Power

20.2%

Maximum Efficiency

Guaranteed Power for Monocrystalline Modules

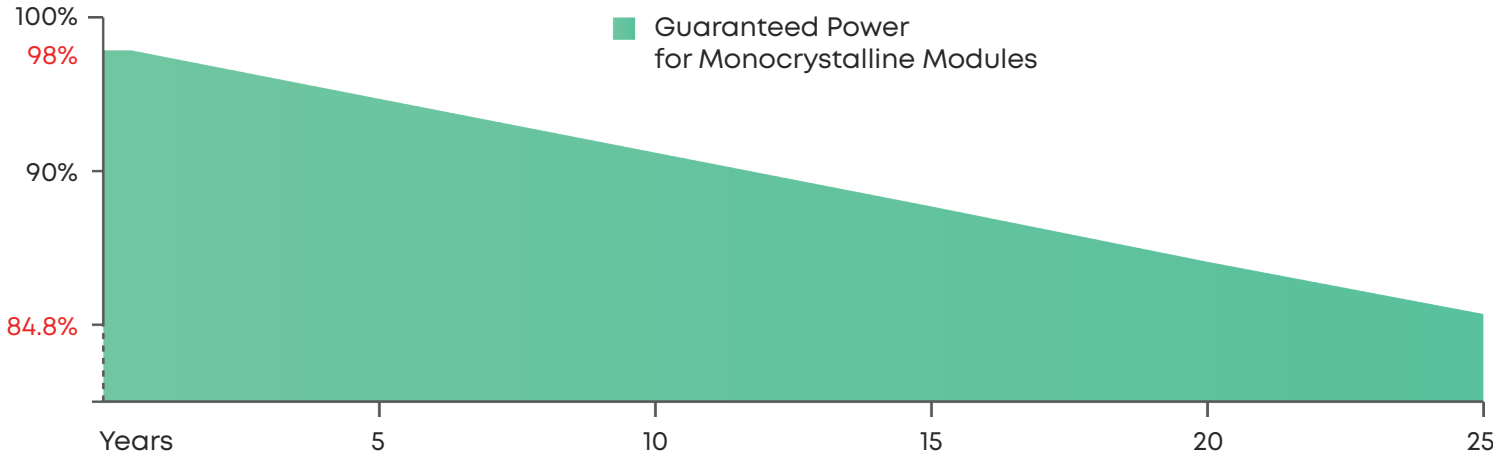

Modular Solar Lamp Pole Solution

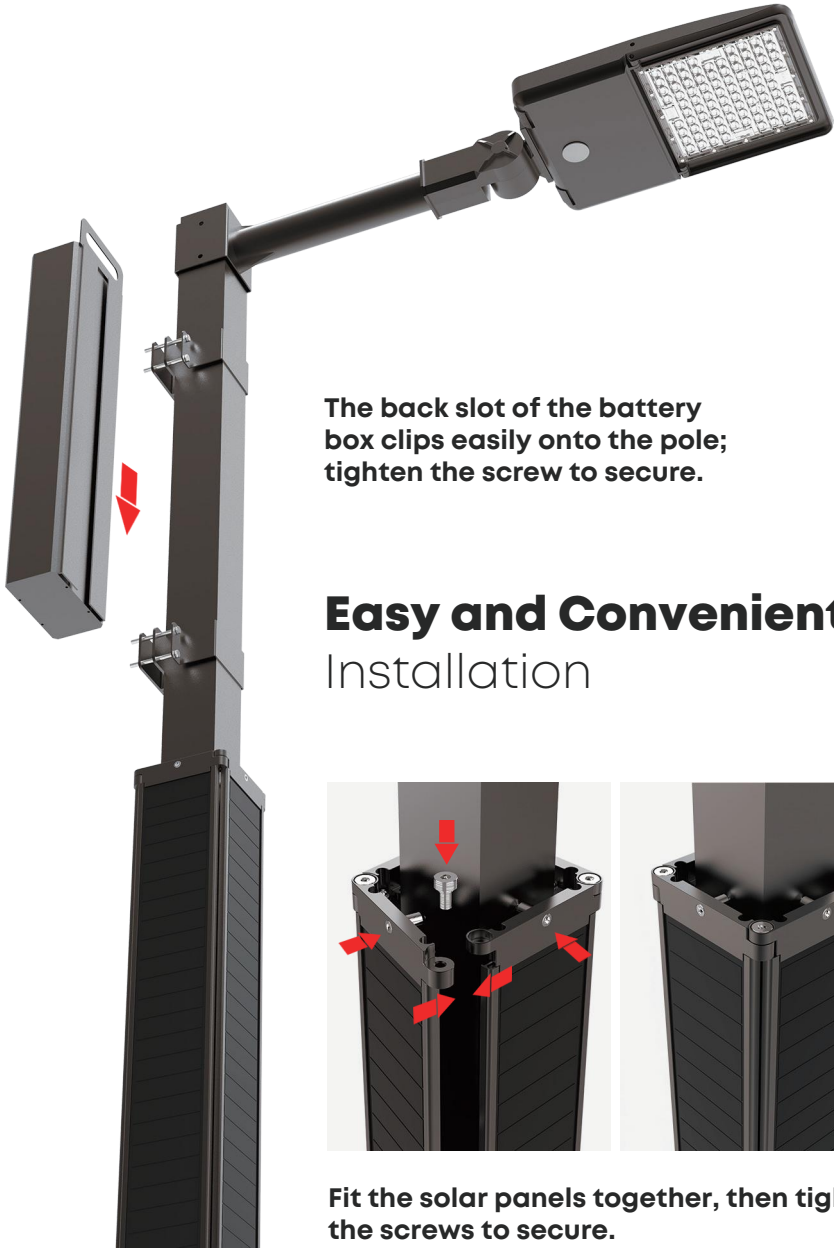

Advantages of Modular Solar Lamp Pole



Integrated Aesthetic Design



Anti-dust accumulation design for easy cleaning



High-Performance Solar Cell Options



Safe & Long-Life Battery

Smart Control Ready

For Efficient Management

Application of **Typical Networking** of Smart Light (optional)



Single Lamp Control

Control street light switch, brightness adjustment, current acquisition. Voltage acquisition, power calculation and power factor functions.



Wireless Network

From the device to the cloud, NB-IoT, GPRS, LTE and other cellular networks are used, without cabling.



Fault Management

The street light can automatically report fault information, troubleshoot faults through the platform, and query historical faults.



Energy Management

Supports online monitoring and storage of energy consumption and configuring energy saving policies.



Intelligent Monitoring

Support remote monitoring and remote control through PC web and mobile APP.



Big Data Analysis

Platform data enables street light fault and energy analysis for maintenance and energy savings.

IoT Connected Ready

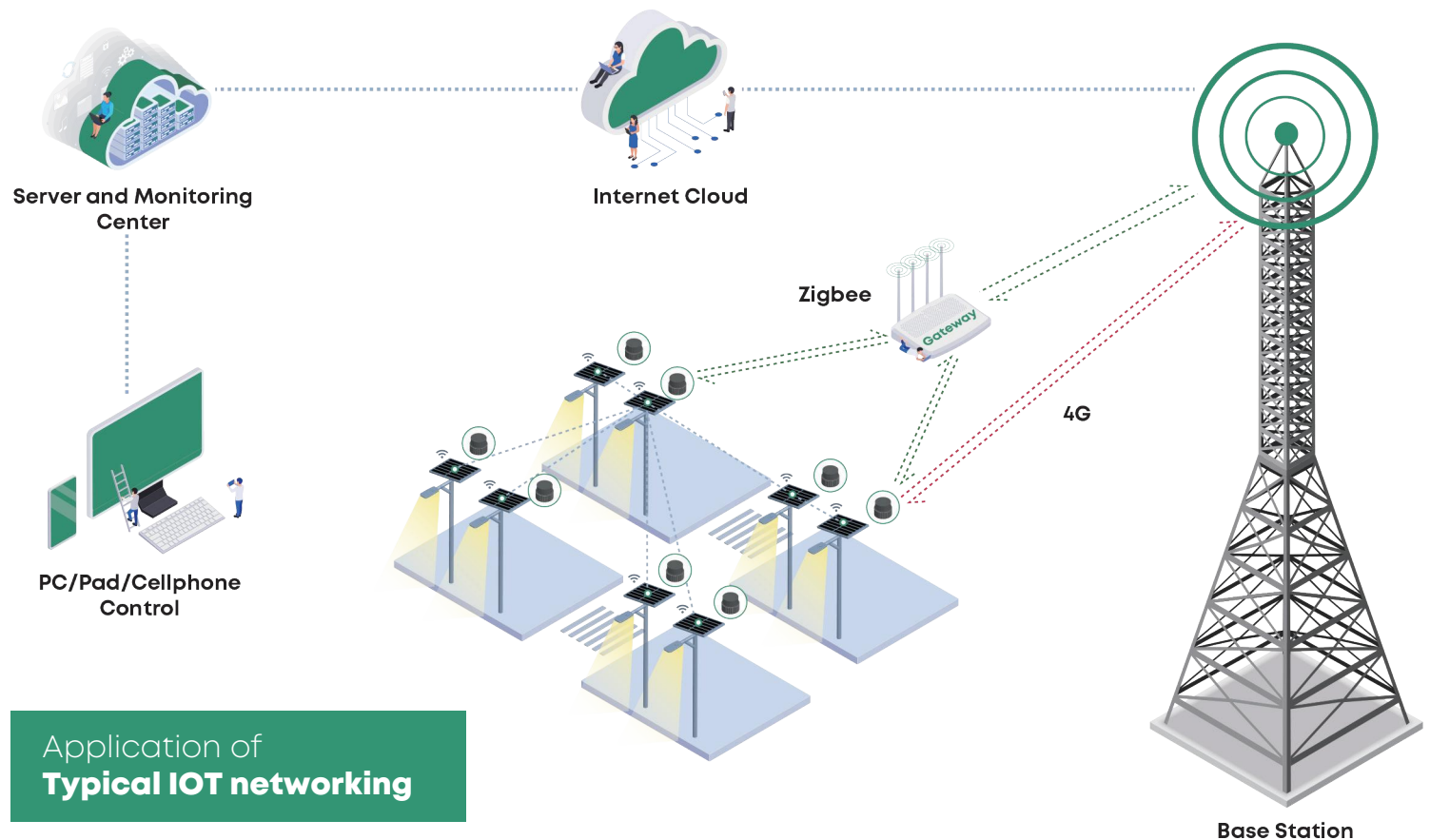

Application of
Typical IOT networking

Parameter Table

Model	SG-115WSL-oT-QS-B	SG-145WSL-oT-QS-B	SG-115WSL-oT-PT-A/B	SG-145WSL-oT-PT-A/B
Power	115W	145W	115W	145W
Work Mode	MPPT,time control		MPPT,time control	
Efficacy(lm/w)	200lm/W		200lm/W	
CCT	3000K~6500K optional		3000K~6500K optional	
CRI	70Ra/80Ra optional		70Ra/80Ra optional	
Solar Panel Installation	Pole installation Monocrystalline silicon cells		Top installation Monocrystalline silicon cells	
Solar Panel	36V 700W	36V 840W	36V 200W	36V 250W
Battery Type	LiFePo4		LiFePo4	
Battery	25.6V 60AH 1536WH	25.6V 75AH 1920WH	25.6V 60AH 1536WH	25.6V 75AH 1920WH
Charing Time	6~8Hrs	6~8Hrs	8.1Hrs	8.1Hrs
Run Time(@full power)	12.0hrs	12.0hrs	12.0hrs	12.0hrs
Ambient Temperature	-10°C to 50°C (14°F to 122°F)		-10°C to 50°C (14°F to 122°F)	
Storage Temperature	-20°C to 45°C (-4°F to 113°F)		-20°C to 45°C (-4°F to 113°F)	
Maximum Autonomy	2-3 day		2-3 day	

Ordering Information

WATTS	VOLTAGE	LED CHIPS	CCT & CRI	DISTRIBUTION	SOLAR PANEL INSTALLATION	BATTERY INSTALLATION	OPTIONS
115WSL-OT	NV1=12.8V DC	L3=LUMILEDS 3030	3070=3000K 70CRI	T301 (85°*145°)	PT=Post Top	Type A	Intelligent Control
145WSL-OT	NV2=25.6V DC	L5=LUMILEDS 5050	4070=4000K 70CRI	T302 (80°*155°)	PH=Post Hoop	Type B	
		S5=SOUEL 5050	5070=5000K 70CRI	T312 (60°*120°)	QS=Quadilateral Solar	Type C	
			5770=5700K 70CRI	T322 (50°*80°)	CS=Cylindrical Solar	Type D	
			6570=6500K 70CRI	T401 (70°*125°)	SS=Semicircular Solar		
			3080=3000K 80CRI	T402 (90°*150°)	HS=Hexigon Solar		
			4080=4000K 80CRI	T501 (150°)			
			5080=5000K 80CRI	T502 (160°)			
			5780=5700K 80CRI	T512 (150°)			

Note:

Battery Installation: Type A=Integrated with solar panel; Type B=Post hoop installed; Type C=Buried underground; Type D=Post inside installed;

Represent temporary unavailable

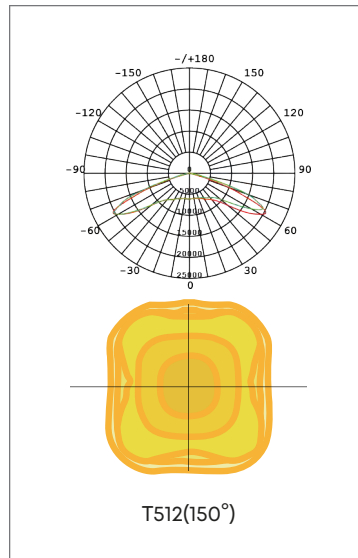
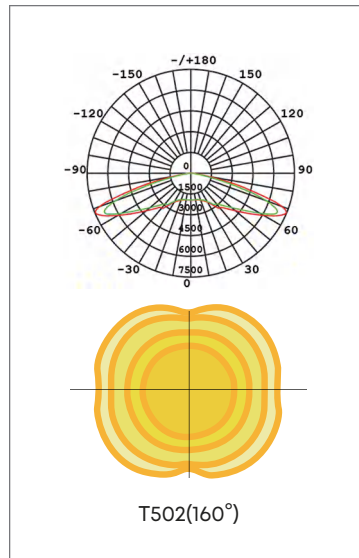
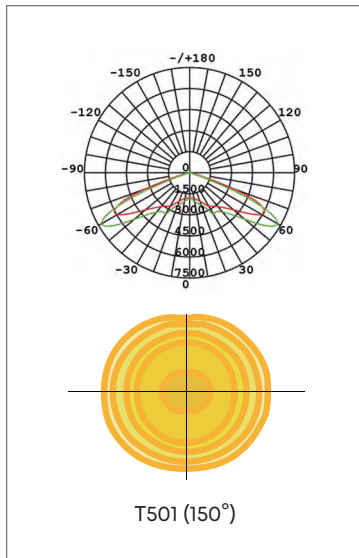
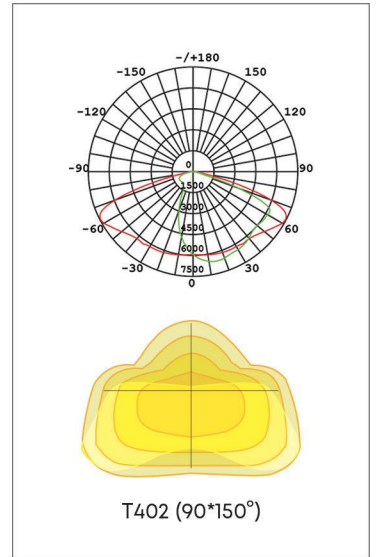
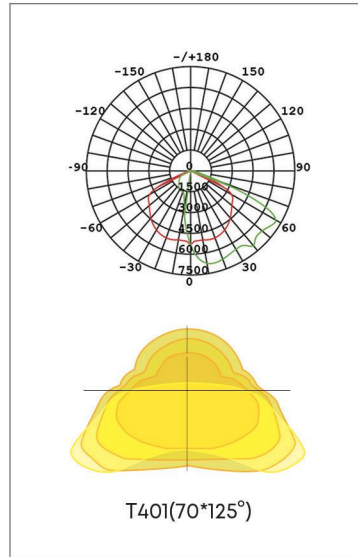
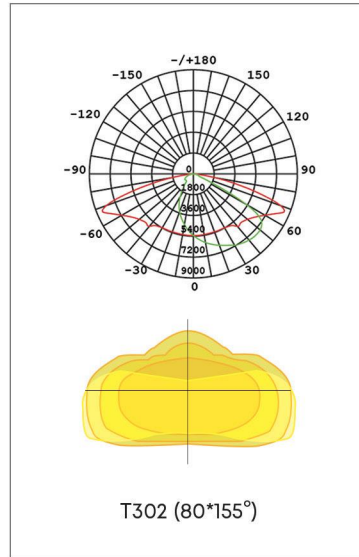
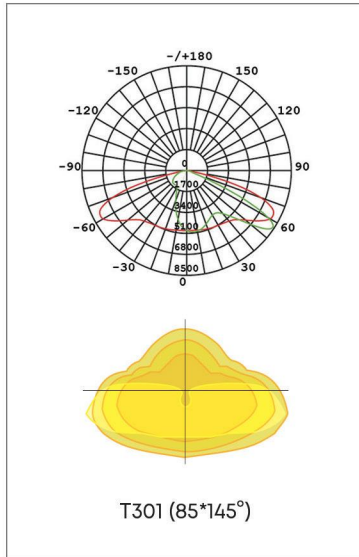

Available in multiple colors

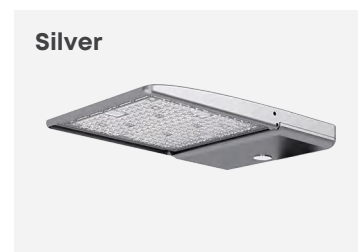
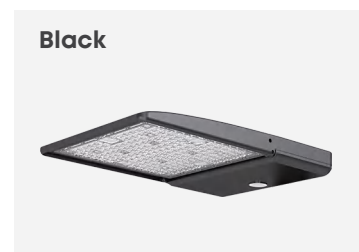
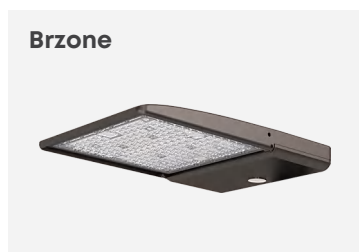

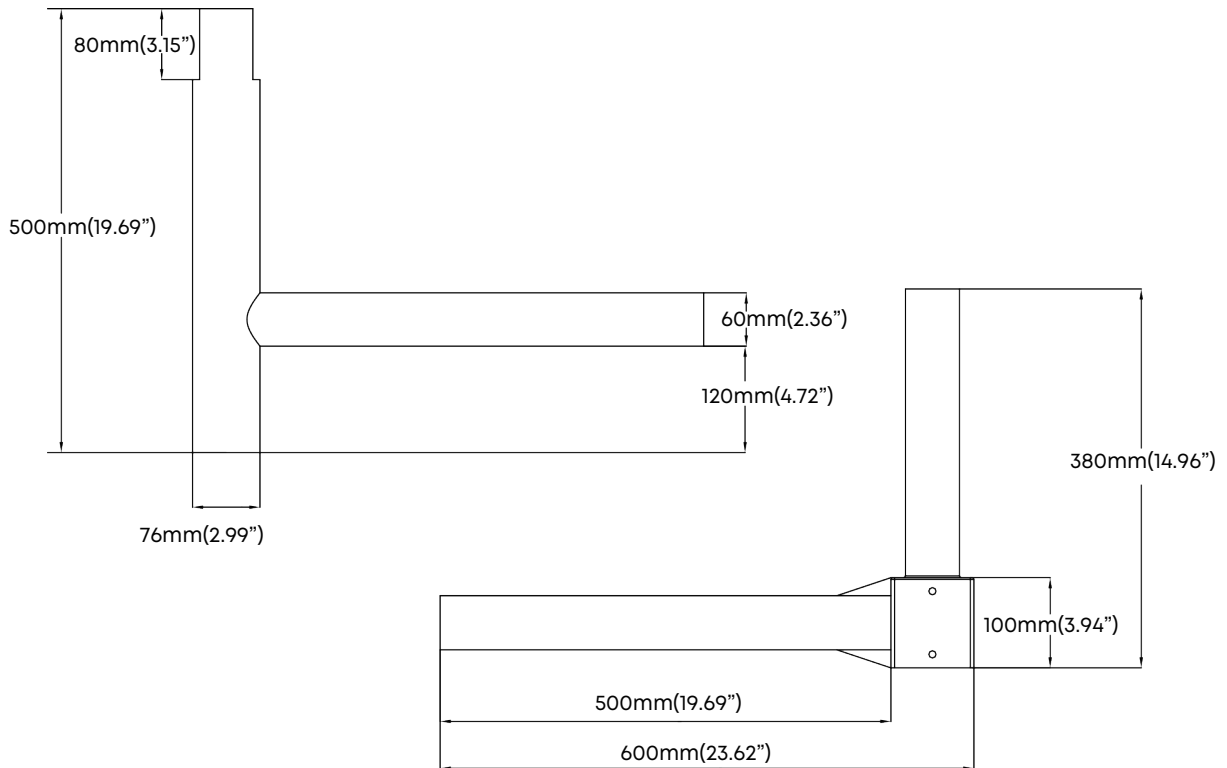
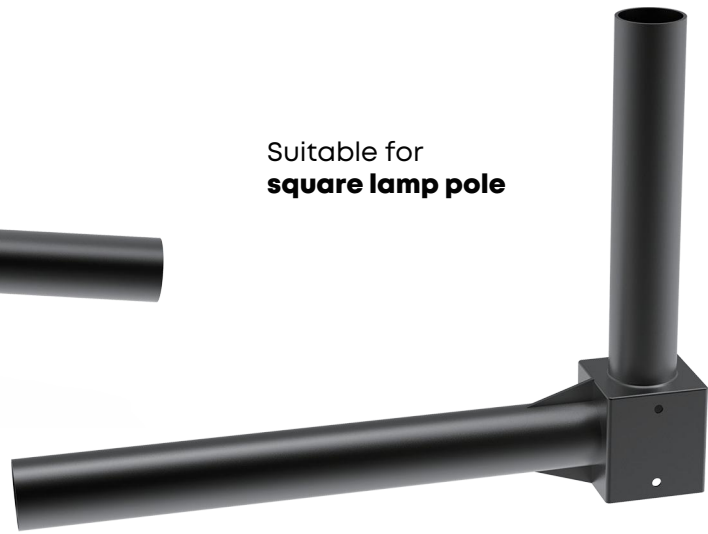
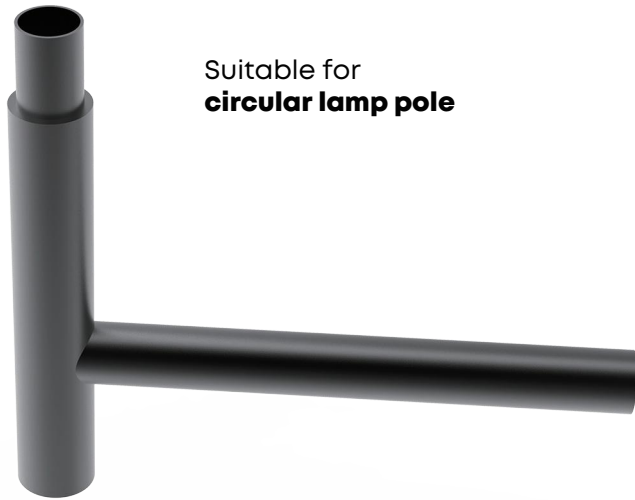

Application Reference

- Parking lot lighting
- Riverside & jogging track
- Urban & residential streets
- Bridges
- Bike & pedestrian paths
- Railway stations & metros
- Squares & pedestrian areas
- Tennis court



